

The Perils Of Falling Hair



Topic

Identification of hair samples

Introduction

Criminalists can learn much from hairs they find at a crime scene. Because the hair from different animals has a different structure, they can discover which animal might have been present, or have been in contact with someone visiting the scene (Locard's Exchange Principle as investigated in Experiment 1.02: Every Contact Leaves A Trace), or have fallen from the head of someone present at the crime scene. In the first part of this experiment, you will look at samples of hair – human, cat, and dog – under a microscope to observe their structure. A strand of hair that has fallen out naturally will look different from one that has been cut, and in the second part of this experiment, you will look at samples of human hair that show this.

Time required

Part A: 30 minutes

Part B: 20 minutes

Materials

microscope (about 100 – 200× magnification) like the one shown in diagram 1 below

18 microscope slides

fine-pointed tweezers

6 samples of hair labeled A – F (use several sources of human hair and a selection of animal hair such as cat, dog, and rabbit)

3 hair samples as follows:

strand of cut hair

hair that has fallen from your head (find strands on your comb or hair brush)

hair plucked from one of your eyebrows

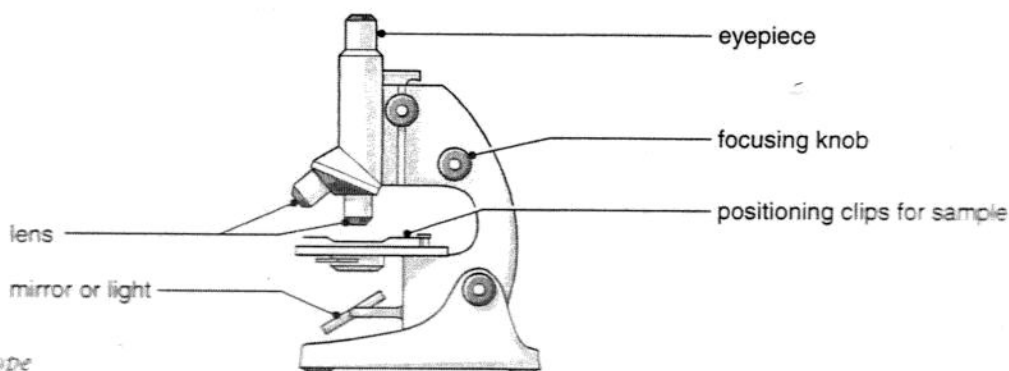

Simple microscope

Safety note



Be careful not to cut yourself with the sharp edges of the microscope slides.

Procedure

Part A: Comparing hair from different animals

1. Look at the color of hair sample A. Record your observations in data table A below.
2. Use the tweezers to place the hair sample on a microscope slide. Cover the hair with a second slide so that it is sandwiched between two slides to form a sample that can be examined in the microscope.
3. Place the sample in the microscope. Adjust the focusing knob and eyepiece until you can see a sharp image of the hair.
4. Draw a picture of the hair structure you can see in the box for sample A in data table A.
5. Repeat steps 1 to 4 for the other hair samples.

DATA TABLE A

Sample	Color	Drawing of hair structure
A		
B		
C		
D		
E		
F		

Part B: Comparing the ends of strands of hair

1. Use the tweezers to place a sample of cut hair in a microscope slide.
2. Cover the hair with a second slide so the hair is sandwiched between two slides to form a sample you can examine in the microscope.
3. Place the sample in the microscope. Adjust the focusing knob until you can see a sharp image of the hair.
4. Draw what you see in the appropriate box in data table B below.
5. Repeat steps 1 to 4 for the strand of fallen hair and the hair from your eyebrow.

DATA TABLE B

Sample	Drawing of structure (show both ends)
Cut hair	
Fallen hair	
Hair from eyebrow	

Analysis*Part A: Comparing hair from different animals*

1. Was it easier to see differences in color when the sample was magnified?
2. Can you see a difference in the structure of the various samples?

Part B: Comparing the ends of strands of hair

1. Was there a difference between the ends of the three samples?

Want to know more?

See Section 10: Our Findings